



# V1000

Compact Current Vector Inverter

Model: VZA

200V Class Single-phase 0.12 to 4.0/5.5 kW

200V Class 3-phase 0.12 to 15/18.5 kW

400V Class 3-phase 0.2 to 15/18.5 kW

## QUICK START GUIDE



# V1000

## Quick Start Guide

---

<b>1 Safety Instructions and General Warnings</b> .....	<b>2</b>
<b>2 Mechanical Installation</b> .....	<b>7</b>
<b>3 Electrical Installation</b> .....	<b>9</b>
<b>4 Keypad Operation</b> .....	<b>15</b>
<b>5 Start Up</b> .....	<b>17</b>
<b>6 Parameter Table</b> .....	<b>22</b>
<b>7 Troubleshooting</b> .....	<b>27</b>

## 1 Safety Instructions and General Warnings

Omron Yaskawa Motion Control B.V. (OYMC) supplies component parts for use in a wide variety of industrial applications. The selection and application of OYMC products remain the responsibility of the equipment designer or end user. OYMC accepts no responsibility for the way its products are incorporated into the final system design. Under no circumstances should any OYMC product be incorporated into any product or design as the exclusive or sole safety control. Without exception, all controls should be designed to detect faults dynamically and fail safely under all circumstances. All products designed to incorporate a component part manufactured by OYMC must be supplied to the end user with appropriate warnings and instructions as to the safe use and operation of that part. Any warnings provided by OYMC must be promptly provided to the end user. OYMC offers an express warranty only as to the quality of its products in conforming to standards and specifications published in the manual. **NO OTHER WARRANTY, EXPRESS OR IMPLIED, IS OFFERED.** OYMC assumes no liability for any personal injury, property damage, losses, or claims arising from misapplication of its products.

### ◆ General Warnings

 <b>WARNING</b>
<ul style="list-style-type: none"><li>• <b>Read and understand this manual before installing, operating or servicing this drive.</b></li><li>• <b>All warnings, cautions, and instructions must be followed.</b></li><li>• <b>All work must be performed by qualified personnel.</b></li><li>• <b>The drive must be installed according to this manual and local codes.</b></li></ul>
<ul style="list-style-type: none"><li>• <b>Heed the safety messages in this manual.</b> The operating company is responsible for any injuries or equipment damage resulting from failure to heed the warnings in this manual.</li></ul>

 <b>WARNING</b>
Indicates a hazardous situation, which, if not avoided, could result in death or serious injury.

The following conventions are used to indicate Safety messages in this manual:

 <b>CAUTION</b>
Indicates a hazardous situation, which, if not avoided, could result in minor or moderate injury.

<b>NOTICE</b>
Indicates a property damage message.

## ◆ Safety Warnings

 <b>WARNING</b>
<b>Electrical Shock Hazard</b>
<ul style="list-style-type: none"><li>• <b>Do not attempt to modify or alter the drive in any way not explained in this manual.</b> Failure to comply could result in death or serious injury. OYMC is not responsible for any modification of the product made by the user. This product must not be modified.</li></ul>
<ul style="list-style-type: none"><li>• <b>Do not touch any terminals before the capacitors have fully discharged.</b> Failure to comply could result in death or serious injury. Before wiring terminals, disconnect all power to the equipment. The internal capacitor remains charged even after the power supply is turned off. The charge indicator LED will extinguish when the DC bus voltage is below 50 Vdc. To prevent electric shock, wait at least five minutes after all indicators are off and measure the DC bus voltage level to confirm safe level.</li></ul>
<ul style="list-style-type: none"><li>• <b>Do not allow unqualified personnel to use equipment.</b> Failure to comply could result in death or serious injury. Maintenance, inspection, and replacement of parts must be performed only by authorized personnel familiar with installation, adjustment, and maintenance of AC drives.</li></ul>
<ul style="list-style-type: none"><li>• <b>Do not remove covers or touch circuit boards while the power is on.</b> Failure to comply could result in death or serious injury.</li></ul>
<ul style="list-style-type: none"><li>• <b>Always ground the motor-side grounding terminal.</b> Improper equipment grounding could result in death or serious injury by contacting the motor case.</li></ul>
<ul style="list-style-type: none"><li>• <b>Do not perform work on the drive while wearing loose clothing, jewelry or without eye protection.</b> Failure to comply could result in death or serious injury. Remove all metal objects such as watches and rings, secure loose clothing, and wear eye protection before beginning work on the drive.</li></ul>
<ul style="list-style-type: none"><li>• <b>Never short the output circuits of the drive.</b> Do not short the output circuits of the drive. Failure to comply could result in death or serious injury.</li></ul>
<b>Sudden Movement Hazard</b>
<ul style="list-style-type: none"><li>• <b>Stay clear of the motor during rotational Auto-Tuning. The motor may start operating suddenly.</b> During automatic starting of equipment, the machine may start moving suddenly, which could result in death or serious injury.</li></ul>

# 1 Safety Instructions and General Warnings

## WARNING

- **System may start unexpectedly upon application of power, resulting in death or serious injury.**

Clear all personnel from the drive, motor, and machine area before applying power. Secure covers, couplings, shaft keys, and machine loads before applying power to the drive.

### Fire Hazard

- **Do not use an improper voltage source.**

Failure to comply could result in death or serious injury by fire.

Verify that the rated voltage of the drive matches the voltage of the incoming power supply before applying power.

- **Do not use improper combustible materials.**

Failure to comply could result in death or serious injury by fire.

Attach the drive to metal or other noncombustible material.

- **Do not connect AC line power to output terminals U, V, and W.**
- **Make sure that the power supply lines are connected to main circuit input terminals R/L1, S/L2, T/L3 (or R/L1 and S/L2 for single-phase power).**

Do not connect the AC power line to the output motor terminals of the drive. Failure to comply could result in death or serious injury by fire as a result of drive damage from line voltage application to output terminals.

- **Tighten all terminal screws to the specified tightening torque.**

Loose electrical connections could result in death or serious injury by fire due to overheating of electrical connections.

## CAUTION

### Crush Hazard

- **Do not carry the drive by the front cover.**

Failure to comply may result in minor or moderate injury from the main body of the drive falling.

### Burn Hazard

- **Do not touch the heatsink or braking resistor hardware until a powered-down cooling period has elapsed.**

## NOTICE

### Equipment Hazard

- **Observe proper electrostatic discharge procedures (ESD) when handling the drive and circuit boards.**  
Failure to comply may result in ESD damage to the drive circuitry.
- **Never connect or disconnect the motor from the drive while the drive is outputting voltage.**  
Improper equipment sequencing could result in damage to the drive.
- **Do not perform a withstand voltage test on any part of the drive.**  
Failure to comply could result in damage to the sensitive devices within the drive.
- **Do not operate damaged equipment.**  
Failure to comply could result in further damage to the equipment.  
Do not connect or operate any equipment with visible damage or missing parts.
- **Install adequate branch circuit short circuit protection per applicable codes.**  
Failure to comply could result in damage to the drive.  
The drive is suitable for circuits capable of delivering not more than 100,000 RMS symmetrical Amperes, 240 Vac maximum (200 V Class) and 480 Vac maximum (400V Class).
- **Do not use unshielded cable for control wiring.**  
Failure to comply may cause electrical interference resulting in poor system performance. Use shielded twisted-pair wires and ground the shield to the ground terminal of the drive.
- **Do not allow unqualified personnel to use the product.**  
Failure to comply could result in damage to the drive or braking circuit.  
Carefully review the braking option instruction manual when connecting a braking option to the drive.
- **Do not modify the drive circuitry.**  
Failure to comply could result in damage to the drive and will void warranty.  
OYMC is not responsible for modification of the product made by the user. This product must not be modified.
- **Check all the wiring to ensure that all connections are correct after installing the drive and connecting other devices.**  
Failure to comply could result in damage to the drive.
- **Do not connect unapproved LC or RC interference suppression filters, capacitors, or overvoltage protection devices to the output of the drive.**  
Using unapproved filters could result in damage to the drive or motor equipment.

# 1 Safety Instructions and General Warnings

---

## ◆ Precautions for CE Low Voltage Directive Compliance

---

This drive has been tested according to European standard EN61800-5-1, and it fully complies with the Low Voltage Directive. The following conditions must be met to maintain compliance when combining this drive with other devices:

Do not use drives in areas with pollution higher than severity 2 and overvoltage category 3 in accordance with IEC664.

Ground the neutral point of the main power supply for 400 V Class drives.

## ◆ Precautions for UL/cUL Standards Compliance

---

This drive is tested in accordance with UL standard UL508C and complies with UL requirements. The following conditions must be met to maintain compliance when using this drive in combination with other equipment:

Do not install the drive to an area greater than pollution severity 2 (UL standard).

Use UL-listed copper wires (rated at 75°C) and closed-loop connectors or CSA-certified ring connectors. For details refer to the instruction manual.

Wire low voltage wires with NEC Class 1 circuit conductors. Refer to national state or local codes for wiring. Use a class 2 (UL regulations) power supply for the control circuit terminal. For details refer to the instruction manual.

This drive has undergone the UL short-circuit test, which certifies that during a short circuit in the power supply the current flow will not rise above 30,000 amps maximum at 240 V for 200 V class drives and 480 V for 400 V class drives.

The drive internal motor overload protection is UL listed and in accordance with the NEC and CEC. The setup can be done using the parameters L1-01/02. For details refer to the instruction manual.

## ◆ Precautions for Using the Safe Disable Function

---

The drive's Safe Disable function is designed in accordance with the EN954-1, safety category 3 and EN61508, SIL2. It can be utilized to perform a safe stop as defined by the EN60204-1, stop category 0 (uncontrolled stop by removal of power). Refer to the instruction manual for details about the application of this function.

## 2 Mechanical Installation

### ◆ Upon Receipt

Please perform the following tasks after receiving the drive:

- Inspect the drive for damage. If the drive appears damaged upon receipt, contact your supplier.
- Verify receipt of the correct model by checking the information on the nameplate. If you have received the wrong model contact your supplier.

### ◆ Installation Environment

For optimum performance life of the drive, install the drive in an environment that meets the conditions listed below.

Environment	Conditions
Installation Area	Indoors
Ambient Temperature	-10 °C to +40 °C (NEMA Type 1) -10 °C to +50 °C (Open-Chassis Type) When using an enclosure panel, install a cooling fan or air conditioner in the area to ensure that the air temperature inside the enclosure does not exceed the specified levels. Do not allow ice to develop on the drive.
Humidity	95% RH or less and free of condensation
Storage Temperature	-20 °C to +60 °C
Surrounding Area	Install the drive in an area free from: <ul style="list-style-type: none"> <li>• oil mist and dust</li> <li>• metal shavings, oil, water or other foreign materials</li> <li>• radioactive materials</li> <li>• combustible materials (e.g., wood)</li> <li>• harmful gases and liquids</li> <li>• excessive vibration</li> <li>• chlorides</li> <li>• direct sunlight</li> </ul>
Altitude	1000 m or less
Vibration	10 - 20 Hz at 9.8 m/s <sup>2</sup> , 20 - 55 Hz at 5.9 m/s <sup>2</sup>
Orientation	Install the drive vertically to maintain maximum cooling effects.

## 2 Mechanical Installation

### ◆ Installation Orientation and Spacing

Always install the drive in an upright position. Leave space around the unit for proper cooling as shown in the figure on the right.

**Note:** Several units can be installed closer together than shown in the figure by using “Side-by-Side” mounting. For details please refer to the instruction manual.

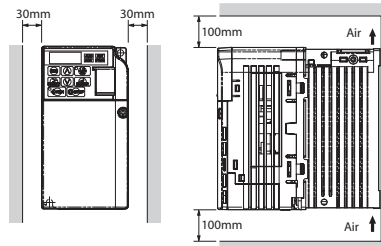

### ◆ Dimensions

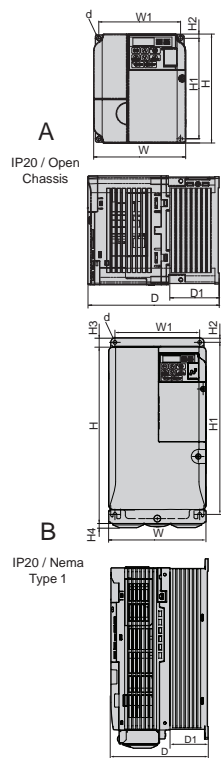

Model VZA*	Dimensions (mm)											Weight (kg)	
	Fig.	W	H	D	W1	H1	H2	H3	H4	D1	d		
BOP1	A	68	128	76	56	118	5	-	-	6.5	M4	0.6	
BOP2		68	128	76	56	118	5	-	-	6.5	M4	0.7	
BOP4		68	128	118	56	118	5	-	-	38.5	M4	1.0	
BOP7		108	128	137.5	96	118	5	-	-	58	M4	1.5	
B1P5		108	128	154	96	118	5	-	-	58	M4	1.5	
B2P2		140	128	163	128	118	5	-	-	65	M4	2.1	
B4P0		under development											
20P1		68	128	76	56	118	5	-	-	6.5	M4	0.6	
20P2		68	128	76	56	118	5	-	-	6.5	M4	0.6	
20P4		68	128	108	56	118	5	-	-	38.5	M4	0.9	
20P7	68	128	128	56	118	5	-	-	38.5	M4	1.1		
21P5	108	128	129	96	118	5	-	-	58	M4	1.3		
22P2	108	128	137.5	96	118	5	-	-	58	M4	1.4		
24P0	140	128	143	128	118	5	-	-	65	M4	2.1		
25P5	B	140	254	140	122	248	6	13	6.2	55	M5	3.8	
27P5		140	254	140	122	248	6	13	6.2	55	M5	3.8	
2011		180	290	163	160	284	8	15	6.2	75	M5	5.5	
2015		220	358	187	192	336	7	15	7.2	78	M5	9.2	
40P2		108	128	81	96	118	5	-	-	10	M4	0.8	
40P4		108	128	99	96	118	5	-	-	28	M4	1.0	
40P7		108	128	137.5	96	118	5	-	-	58	M4	1.4	
41P5		A	108	128	154	96	118	5	-	-	58	M4	1.5
42P2			108	128	154	96	118	5	-	-	58	M4	1.5
43P0			108	128	154	96	118	5	-	-	58	M4	1.5
44P0	140		128	143	128	118	5	-	-	65	M4	2.1	
45P5	B		140	254	140	122	248	6	13	6	55	M5	3.8
47P5			140	254	140	122	248	6	13	6.2	55	M5	3.8
4011			180	290	143	160	284	8	15	6	55	M5	5.2
4015			180	290	163	160	284	8	15	6	75	M5	5.5

# 3 Electrical Installation

The figure below shows the main and control circuit wiring.

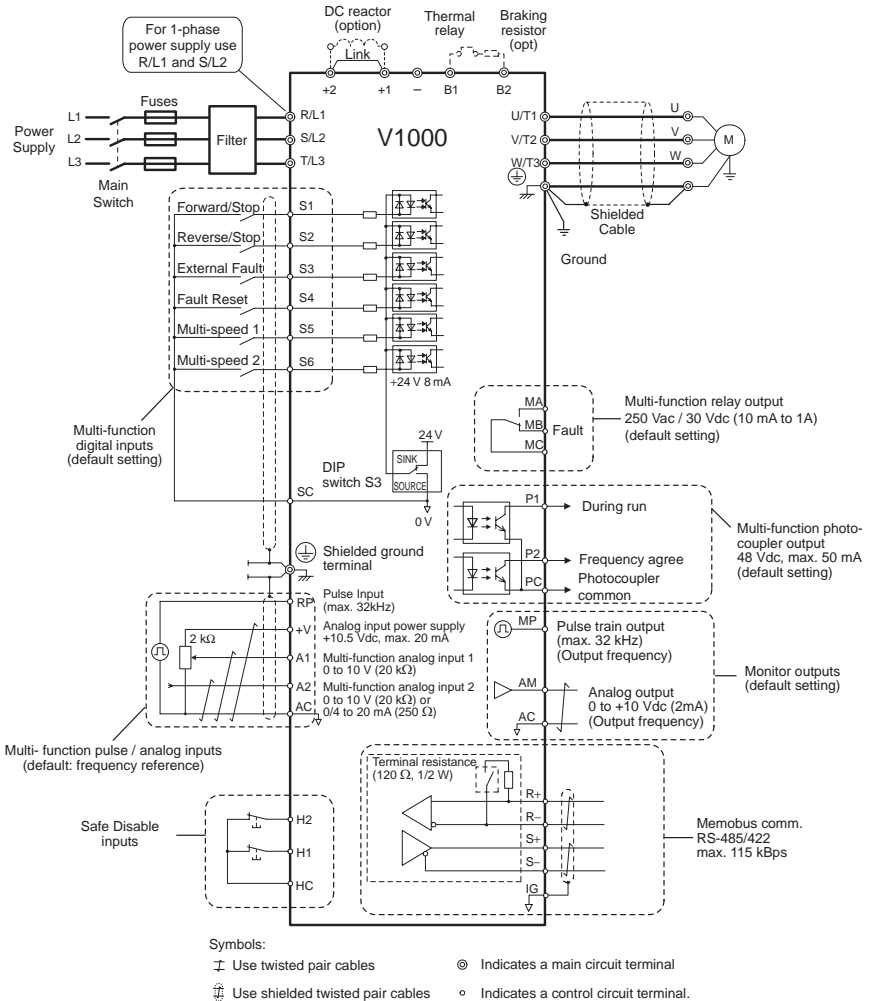

## 3 Electrical Installation

### ◆ Wiring Specification

#### ■ Main Circuit

Use the fuses and line filters listed up in the table below when wiring the main circuit. Make sure not to exceed the given tightening torque values.

Model VZA*	EMC Filter Type		Main Fuse (Ferraz)	Recom. Motor cable [mm <sup>2</sup> ]	Main Circuit Terminal Sizes		
	Rasmi	Schaffner			R/L1,S/L2,T/L3, U/T1,V/T2,W/T3, -, +1, +2	B1, B2	GND
B0P1	A1000-FIV1010-RE	A1000-FIV1010-SE	TRS5R	1.5	M3.5	M3.5	M3.5
B0P2			TRS10R	1.5	M3.5	M3.5	M3.5
B0P4			TRS20R	1.5	M3.5	M3.5	M3.5
B0P7			TRS35R	2.5	M4	M4	M4
B1P5	A1000-FIV1020-RE	A1000-FIV1020-SE	TRS50R	4	M4	M4	M4
B2P2	A1000-FIV1030-RE	A1000-FIV1030-SE	TRS60R	4	M4	M4	M4
B4P0	under development						
20P1	A1000-FIV20010-RE	A1000-FIV20010-SE	TRS5R	1.5	M3.5	M3.5	M3.5
20P2			TRS5R	1.5	M3.5	M3.5	M3.5
20P4			TRS10R	1.5	M3.5	M3.5	M3.5
20P7			TRS15R	1.5	M3.5	M3.5	M3.5
21P5			TRS25R	2.5	M4	M4	M4
22P2	A1000-FIV2020-RE	A1000-FIV2020-SE	TRS35R	4	M4	M4	M4
24P0	A1000-FIV2030-RE	A1000-FIV2030-SE	TRS60R	4	M4	M4	M4
25P5	A1000-FIV2060-RE	A1000-FIV2050-SE	A6T70<1>	6	M4	M4	M5
27P5			A6T100<1>	10	M4	M4	M5
2011	A1000-FIV2100-RE	-	A6T150<1>	16	M6	M5	M6
2015			A6T200<1>	25	M8	M5	M6
40P2			TRS2.5R	2.5	M4	M4	M4
40P4	A1000-FIV30005-RE	A1000-FIV30005-SE	TRS5R	2.5	M4	M4	M4
40P7	A1000-FIV3010-RE	A1000-FIV3010-SE	TRS10R	2.5	M4	M4	M4
41P5			TRS20R	2.5	M4	M4	M4
42P2			TRS20R	2.5	M4	M4	M4
43P0			TRS20R	2.5	M4	M4	M4
44P0			TRS30R	4	M4	M4	M4
45P5	A1000-FIV3030-RE	A1000-FIV3030-SE	A6T50<1>	4	M4	M4	M5
47P5			A6T60<1>	6	M4	M4	M5
4011	A1000-FIV3050-RE	-	A6T70<1>	10	M5	M5	M5
4015			A6T80<1>	10	M5	M5	M6

<1> For UL compliance a different fuse type has to be used. For details refer to the instruction manual.

#### Tightening Torque Values

Tighten the main circuit terminals using the torque values provided by the table below.

Terminal Size	M3.5	M4	M5	M6	M8
Tightening Torque [Nm]	0.8 to 1.0	1.2 to 1.5	2.0 to 2.5	4.0 to 5.0	9.0 to 11.0

### ■ Control Circuit

The control terminal board is equipped with screwless terminals. Always use wires within the specification listed below. For safe wiring it is recommended to use solid wires or flexible wires with ferrules. The stripping length respectively ferrule length should be 8 mm.

Wire Type	Wire size
Solid	0.2 to 1.5 mm <sup>2</sup>
Flexible	0.2 to 1.0 mm <sup>2</sup>
Flexible with ferrule	0.25 to 0.5 mm <sup>2</sup>

### ◆ EMC Filter Installation

This drive has been tested in accordance with European standards EN61800-3. In order to comply to the EMC standards, wire the main circuit as described below.

1. Install an appropriate EMC noise filter to the input side. See the list above or refer to the instruction manual for details.
2. Place the drive and EMC noise filter in the same enclosure.
3. Use braided shield cable for the drive and motor wiring
4. Remove any paint or dirt from ground connections for minimal ground impedance
5. Install an AC reactor at drives smaller than 1 kW for compliance with the EN61000-3-2. Refer to the instruction manual or contact your supplier for details

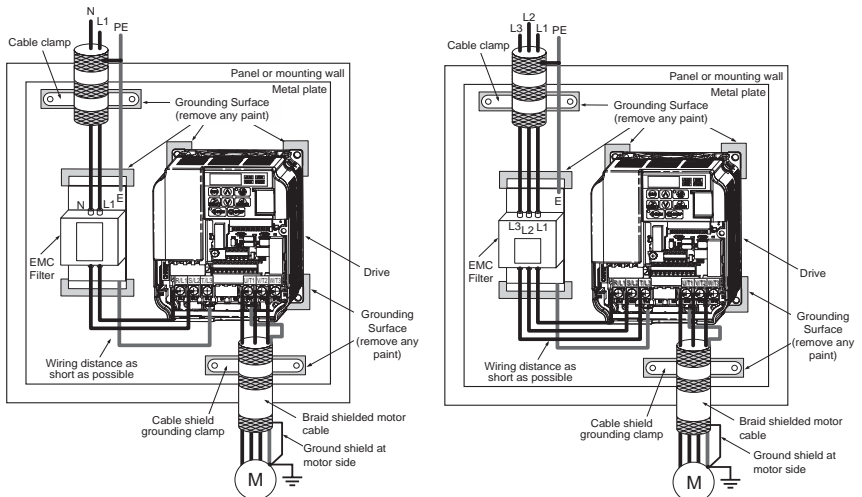

**EMC Standards Compliant Wiring of Single- and Three Phase Units**

### ◆ Main and Control Circuit Wiring

---

#### ■ Wiring the Main Circuit Input

Consider the following precautions for the main circuit input.

- Use only circuit breakers that have been designed specifically for drives.
- If using a ground fault circuit breaker, make sure that it can detect both DC and high frequency current.
- If using an input switch is used, make sure that the switch does not operate not more than once every 30 minutes.
- Use a DC reactor or AC reactor on the input side of the drive:
- To suppress harmonic current.
- To improve the power factor on the power supply side.
- When using an advancing capacitor switch.
- With a large capacity power supply transistor (over 600 kVA).

#### ■ Wiring the Main Circuit Output

Consider the following precautions for the output circuit wiring.

- Do not connect any other load than a 3 phase motor to the drives output.
- Never connect a power source to the drives output.
- Never short or ground the output terminals.
- Do not use phase correction capacitors.
- If using a contactor between the drive and motor, it should never be operated when the drive is outputting a voltage. Operating while there is voltage output can cause large peak currents, thus tripping the over current detection or damage the drive.

#### ■ Ground Connection

Take the following precautions when grounding the drive.

- Never share the ground wire with other devices such as welding machines, etc.
- Always use a ground wire, that complies with electrical equipment technical standards. Keep ground wires as short as possible. Leakage current is caused by the drive. Therefore, if the distance between the ground electrode and the ground terminal is too long, potential on the ground terminal of the drive will become unstable.
- When using more than one drive, do not to loop the ground wire.

#### ■ Control Circuit Wiring Precautions

Consider the following precautions for wiring the control circuits.

- Separate control circuit wiring from main circuit wiring and other high-power lines.
- Separate wiring for control circuit terminals MA, MB, MC (contact output) from wiring to other control circuit terminals.

- For external control power supply use a UL Listed Class 2 power supply.
- Use twisted-pair or shielded twisted-pair cables for control circuits to prevent operating faults.
- Ground the cable shields with the maximum contact area of the shield and ground.
- Cable shields should be grounded on both cable ends.

#### ■ Main Circuit Terminals

Terminal	Type	Function
R/L1, S/L2, T/L3	Main circuit power supply input	Connects line power to the drive. Drives with single-phase 200 V input power use terminals R/L1 and S/L2 only (T/L3 is not used).
U/T1, V/T2, W/T3	Drive output	Connects to the motor.
B1, B2	Braking resistor	For connecting a braking resistor or the braking resistor unit option.
+1, +2	DC reactor connection	Linked at shipment. Remove the link to install a DC choke.
+1, -	DC power supply input	For connecting a DC power supply.
 (2 terminals)	Ground Terminal	For 200 V class: Ground with 100 Ω or less For 400 V class: Ground with 10 Ω or less

#### ■ Main Circuit Terminals

The figure below shows the control circuit terminal arrangement. The drive is equipped with screwless terminals

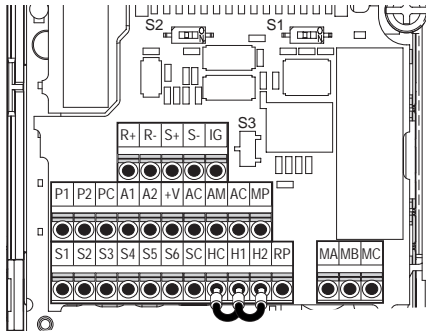

There are three DIP switches, S1 to S3, located on the terminal board

<b>SW1</b>	Switches analog input A2 between voltage and current input
<b>SW2</b>	Enables or disables the internal RS422/485 comm. port terminal resistance.
<b>SW3</b>	Used to select sourcing (PNP)/sinking (NPN, default) mode for the digital inputs (PNP requires external 24 Vdc power supply)

## 3 Electrical Installation

### ■ Control Circuit Terminals

Type	No.	Terminal Name (Signal)	Function (Signal Level), Default Setting
Multi-Function Digital Inputs	S1 to S6	Multi-function digital input 1 to 6	Photocoupler inputs, 24 Vdc, 8 mA Note: Drive preset to sinking mode (NPN). When using source mode, set DIP switch S3 to "SOURCE" and use an external 24 Vdc ( $\pm 10\%$ ) power supply.
	SC	Multi-function input common	Sequence common
Multi-Function Analog/Pulse Inputs	RP	Pulse train input	Response frequency: 0.5 to 32 kHz, Duty: 30 to 70%, High: 3.5 to 13.2 V, Low: 0.0 to 0.8 V, input impedance: 3 k $\Omega$ )
	+V	Analog input power supply	+10.5 V (max allowable current 20 mA)
	A1	Multi-function analog input 1	0 to +10 Vdc (20 k $\Omega$ ) resolution 1/1000
	A2	Multi-function analog input 2	0/4 to 20 mA (250 $\Omega$ ) resolution: 1/500 (A2 only)
Safe Disable Inputs	AC	Frequency reference common	0 V
	HC	Safe Disable Input common	+24 V (max 10 mA allowed)
	H1	Safe Disable Input 1	One or both open: Drive output disabled (time from input open to drive output switch off is less than 1 ms) Both Closed: Normal operation
H2	Safe Disable Input 2		
Multi-Function Relay Output	MA	N.O. (fault)	Digital relay output 30 Vdc, 10 mA to 1 A 250 Vac, 10 mA to 1 A
	MB	N.C. output (fault)	
	MC	Digital output common	
Multi-Function PHC Output	P1	Photocoupler output 1	Digital photocoupler output 48 Vdc, 0 to 50 mA
	P2	Photocoupler output 2	
	PC	Photocoupler output common	
Monitor Output	MP	Pulse train output	32 kHz (max)
	AM	Analog monitor output	0 to 10 Vdc (2 mA or less), Resolution: 1/1000 (10 Bit)
	AC	Monitor common	0 V
MEMO-BUS/Communication	R+	Communications input (+)	MEMOBUS/Modbus communication: RS-485 or RS-422, 115.2 kbps (max)
	R-	Communications input (-)	
	S+	Communications output (+)	
	S-	Communications output (-)	

**NOTICE!** The terminals HC, H1, H2 are used for the Safe Disable function which cuts the output voltage in less than 1 ms if at least one of the inputs H1 or H2 is opened. It is designed in accordance with the EN954-1, safety category 3 and EN61508, SIL2. It and can be utilized to perform a safe stop as defined by the EN60204-1, stop category 0. Do not remove the wire link between HC, H1, or H2 unless the Safe Disable function is used.

## 4 Keypad Operation

### ◆ LED Operator and Keys

The LED operator is used to program the drive, to start/stop it, and to display fault information. The LEDs indicate the drive status.

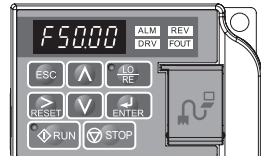

### ■ Keys and Functions

Display	Name	Function
	Data Display Area	Displays the frequency reference, parameter number, etc.
	ESC Key	Returns to the previous menu.
	RESET Key	Moves the cursor to the right. Resets a fault.
	RUN Key	Starts the drive in the LOCAL mode. The Run LED • is on, when the drive is operating the motor. • flashes during deceleration to stop or when the frequency reference is 0. • flashes quickly the drive is disabled by a DI, the drive was stopped using a fast stop DI or a run command was active during power up.
	Up Arrow Key	Scrolls up to select parameter numbers, setting values, etc.
	Down Arrow Key	Scrolls down to select parameter numbers, setting values, etc.
	STOP Key	Stops the drive.
	ENTER Key	Selects modes, parameters and is used to store settings.
	LO/RE Selection Key	Switches drive control between the operator (LOCAL) and the control circuit terminals (REMOTE). The LED is on when the drive is in the LOCAL mode (operation from keypad).
	ALM LED Light	Flashing: The drive is in an alarm state. On: The drive is in a fault state and the output is stopped.
	REV LED Light	On: The motor rotation direction is reverse. Off: The motor rotation direction is forward.
	DRV LED Light	On: The drive is ready to operate the motor. Off: The drive is in the Verify, Setup, Parameter Setting or Auto tuning mode.
	FOUT LED Light	On: The output frequency is displayed on the data screen. Off: Anything else than the output frequency is displayed on the data screen.

# 4 Keypad Operation

## ◆ Menu Structure and Modes

The following illustration explains the operator keypad menu structure.

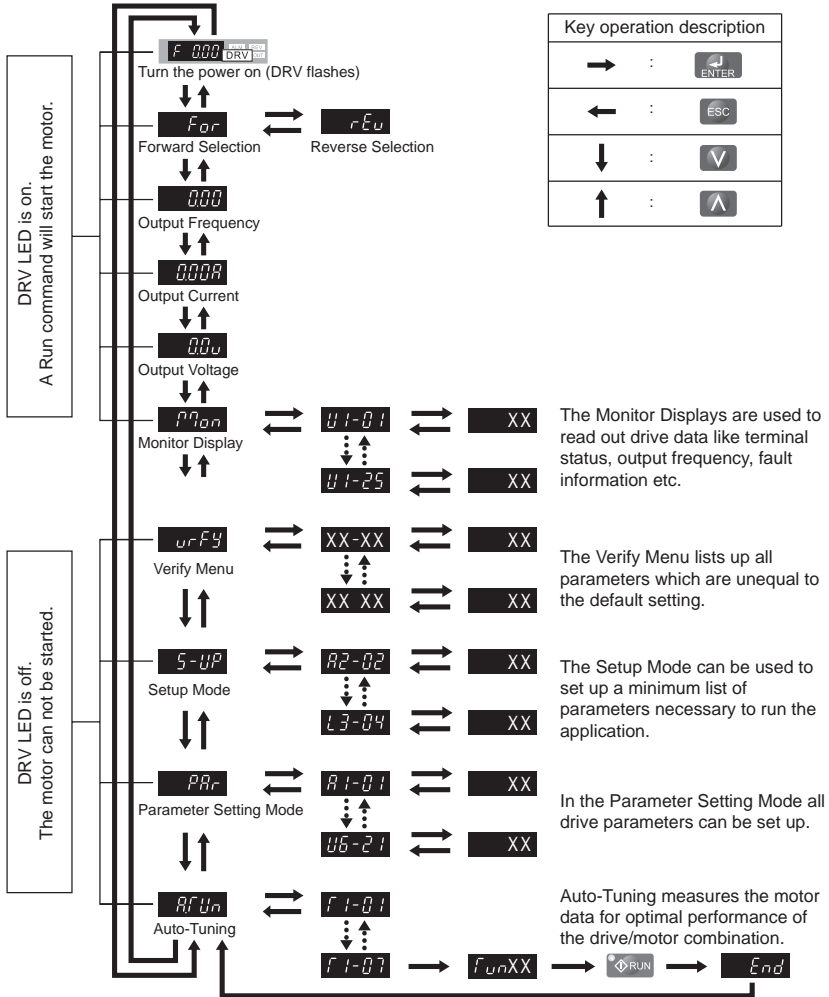

## 5 Start Up

### ◆ Drive Setup Procedure

The illustration below shows the basic setup procedure. Each step is explained more detailed on the following pages.

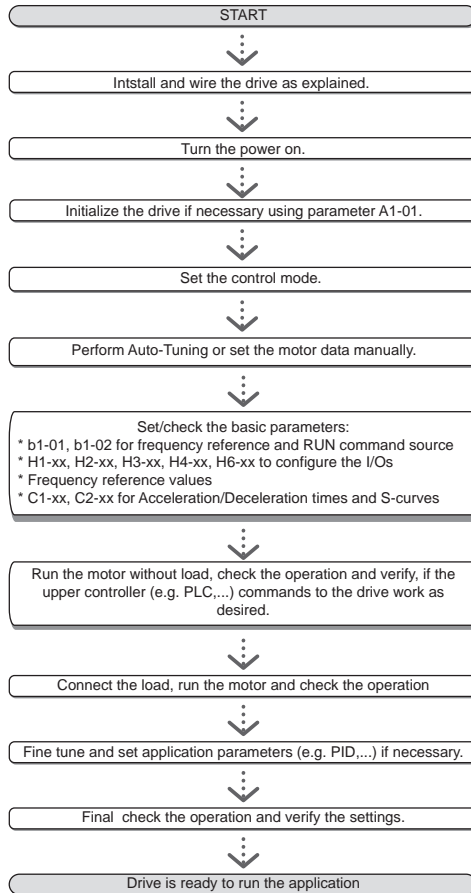

## 5 Start Up

### ◆ Power On

Before turning on the power supply,

- Make sure all wires are connected properly.
- Make sure no screws, loose wire ends or tools are left in the drive.
- After turning the power on, the drive mode display should appear and no fault or alarm should be displayed.

### ◆ Control Mode Selection (A1-02)

There are three control modes available. Select the control mode that best suits the applications the drive will control.

Control Mode	Parameter	Main Applications
V/f Control	A1-02 = 0 (default)	<ul style="list-style-type: none"><li>• General variable speed applications, particularly useful for running multiple motors from a single drive</li><li>• When replacing a drive in which parameter settings are unknown</li></ul>
Open Loop Vector Control (OLV)	A1-02 = 2	<ul style="list-style-type: none"><li>• General variable speed applications</li><li>• Applications requiring high precision, high speed control</li></ul>
PM Open Loop Vector Control	A1-02 = 5	<ul style="list-style-type: none"><li>• Derated torque-load applications employing permanent magnet motors (SPM, IPM) and energy savings.</li></ul>

### ◆ Auto-Tuning (T1-□□)

Auto-Tuning automatically sets up the motor data relevant drive parameters. Three different modes are supported

Tuning Mode	Parameter	Control Mode	Description
Rotational Auto-Tuning	T1-01 = 0	OLV	Perform when setting the drive to operate in Open Loop Vector control. The motor must be able to rotate without load during the tuning process in order to achieve a high accuracy.
Terminal resistance tuning	T1-01 = 2	OLV, V/f control	Perform in V/f control if the motor cable is long or if the cable has been changed.
Rotational Auto-Tuning for Energy Saving	T1-01 = 3	V/f control	Perform when using Energy Saving or Speed Search. The motor must be able to rotate without load in order to achieve a high tuning accuracy.

#### CAUTION

Never touch the motor until the Auto-Tuning is finished. Even though the motor may not be rotating when Auto-Tuning, voltage is still applied to the motor during the tuning process.

For Auto-Tuning enter the Auto-Tuning menu and perform the steps shown in the figure below. The number of name plate data to be entered depends on the selected type of Auto-Tuning. This example shows Rotational Auto-Tuning.

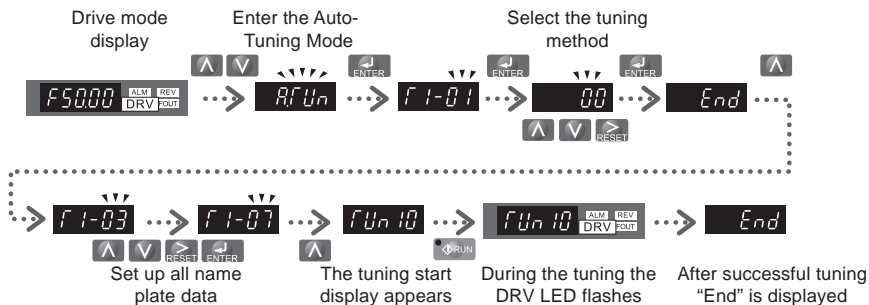

If Auto-Tuning can not be performed for some reason (no-load operation impossible etc.), then set up the maximum frequency and voltage in the E1-□□ parameters and enter the motor data manually into the E2-□□ parameters.

**NOTICE!** *The Safe Disable inputs must be closed during Auto-Tuning.*

## 5 Start Up

---

### ◆ Reference and Run Source

---

The drive has a LOCAL and a REMOTE mode. The LED in the LO/RE key indicates the drive status.

Status	Description	LO/RE LED
LOCAL	The Run/ Stop command and the frequency reference are entered at the operator keypad.	ON
REMOTE	The Run command source entered in parameter b1-02 and the frequency reference source entered in parameter b1-02 are used.	OFF

If the drive is operated in the REMOTE mode, make sure that the correct sources for the frequency reference and run command are set in parameters b1-01/02 and that the drive is in the REMOTE mode.

### ◆ I/O Setup

---

#### ■ Multi-Function Digital Inputs (H1-□□)

The function of each digital input can be assigned in the H1-□□ parameters. The default setting functions can be seen in the connection diagram on [page 9](#).

#### ■ Multi-Function Digital Outputs (H2-□□)

The function of each digital output can be assigned in the H2-□□ parameters. The default setting functions can be seen in the connection diagram on [page 9](#). The setting value of these parameters consist of 3 digits, where the middle and right digit set the function and the left digit sets the output characteristics (0: Output as selected; 1: Inverse output).

#### ■ Multi-Function Analog Inputs (H3-□□)

The function of each analog input can be assigned in the H3-□□ parameters. The default setting of both inputs is “Frequency reference”. Input A1 is set for 0 to 10V input and A2 is set for 4-20 mA input. The addition of both input values builds the frequency reference.

**NOTICE!** *If the input signal level of input A2 is switched between voltage and current, make sure that DIP switch S1 is in the correct position and parameter H3-09 is set up correctly.*

#### ■ Monitor Output (H4-□□)

Use the H4-□□ parameters to set up the output value of the analog monitor output and to adjust the output voltage levels. The default monitor value setting is “Output frequency”.

## ◆ Frequency Reference and Acceleration/ Deceleration Times

### ■ Frequency Reference Setup(b1-01)

Set parameter b1-01 according to the frequency reference used.

b1-01	Reference source	Frequency reference input
0	Operator keypad	Set the frequency references in the d1-□□ parameters and used digital inputs to switch over between different reference values.
1	Analog input	Apply the frequency reference signal to terminal A1 or A2.
2	Serial Comm.	Serial Communications using the RS422/485 port
3	Option Board	Communications option card
4	Pulse input	Set the frequency reference at terminal RP using a pulse train signal.

### ■ Acceleration/ Deceleration Times and S-Curves

There are four sets of acceleration and deceleration times which can be set in the C1-□□ parameters. The default activated accel/ decel times are C1-01/02. Adjust these times to the appropriate values required by the application. If necessary S-curves can be activated in the C2-□□ parameters for softer accel/ decel start and end.

## ◆ Test Run

Perform the following steps to start up the machine after all parameter settings have been done.

1. Run the motor without load and check if all input, outputs and the sequence work as desired.
2. Connect the load to the motor.
3. Run the motor with load and make sure that there is no vibrations, hunting or motor stalling occurs.

After taking the steps listed above, the drive should be ready to run the application and perform the basic functions. For special setups like PID control etc. refer to the instruction manual.

### 6 Parameter Table

This parameter table shows the most important parameters. Default settings are bold type. Refer to the instruction manual for a complete list of parameters.

Par.	Name	Description
Initialization Parameters		
A1-01	Access Level Selection	Selects which parameters are accessible via the digital operator. 0:Operation only 1:User Parameters <b>2:Advanced Access Level</b>
A1-02	Control Method Selection	Selects the Control Method of the drive. <b>0: V/f Control</b> 2: Open Loop Vector (OLV) 5: PM Open Loop Vector (PM) Note: Not initialized with A1-03!
A1-03	Initialize Parameters	Resets all parameters to default. (returns to 0 after initialization) No Initialize 1110: User Initialize (The user must first set user parameter values and then store them using parameter o2-03) 2220: 2-Wire Initialization 3330: 3-Wire Initialization
Operation Mode Selection		
b1-01	Frequency Reference Selection	0:Operator - d1-□□ values <b>1:Analog input A1 or A2</b> 2:Serial Com - RS-422/485 3:Option board 4:Pulse Input (Terminal RP)
b1-02	Run Command Selection	0:Operator - RUN and STOP keys <b>1:Terminals - Digital Inputs</b> 2:Serial Com - RS-422/485 3:Option board connected

Par.	Name	Description
b1-03	Stopping Method Selection	Selects the stopping method when the run command is removed. <b>0:Ramp to Stop</b> 1:Coast to Stop 2:DC Injection Braking to Stop 3:Coast with Timer (a new run command is ignored if received before the timer expires)
b1-04	Reverse Operation Selection	<b>0:Reverse enabled</b> 1:Reverse prohibited
b1-14	Phase Order Selection	Switches the output phase order. <b>0:Standard</b> 1:Switch phase order
DC Injection Braking		
b2-01	DC Injection Braking Start Frequency	Sets the frequency at which DC Injection Braking starts when Ramp to Stop (b1-03 = 0) is selected. If b2-01 < E1-09, DC Injection Braking starts at E1-09.
b2-02	DC Injection Braking Current	Sets the DC Injection Braking current as a percentage of the drive rated current. In OLV the DC excitation current is determined by E2-03.
b2-03	DC Inj. Braking Time at Start	Sets the time of DC Injection Braking at start in units of 0.01 seconds. Disabled when set to 0.00 seconds.
b2-04	DC Inj. Braking Time at Stop	Sets the DC Injection Braking time at stop. Disabled when set to 0.00 seconds.
Acceleration/ Deceleration		
C1-01	Accel Time 1	Sets the acceleration time 1 from 0 to the max. output frequency.
C1-02	Decel Time 1	Sets the deceleration time 2 from the max. output frequency to 0.

Par.	Name	Description
C1-03 to C1-08	Accel/Decel Times 2 to 4	Set the accel/ decel times 2 to 4 (set like C1-01/02)
C2-01	S-Curve 1	S-curve at acceleration start.
C2-02	S-Curve 2	S-curve at acceleration end.
C2-03	S-Curve 3	S-curve at deceleration start.
C2-04	S-Curve 4	S-curve at deceleration end.
Slip Compensation		
C3-01	Slip Compensation Gain	<ul style="list-style-type: none"> <li>• Increase if the speed is lower than the frequency reference</li> <li>• Decrease if the speed is higher than the frequency reference.</li> </ul>
C3-02	Slip Compensation Delay Time	<ul style="list-style-type: none"> <li>• Decrease the setting when the slip compensation is too slow.</li> <li>• Increase the setting when the speed is not stable.</li> </ul>
Torque Compensation		
C4-01	Torque Compensation Gain	<ul style="list-style-type: none"> <li>• Increase this setting when the torque response is slow</li> <li>• Decrease this setting when speed/torque oscillations occur.</li> </ul>
C4-02	Torque Compensation Delay Time	<ul style="list-style-type: none"> <li>• Increase this setting when speed / torque oscillations occur.</li> <li>• Decrease the setting when the torque response is too slow.</li> </ul>
Duty Mode and Carrier Frequency		
C6-01	Normal/ Heavy Duty Selection	<b>0: Heavy Duty (HD)</b> <b>Constant torque applications</b> 1: Normal Duty (ND) Variable torque application
C6-02	Carrier Frequency Selection	1: 2.0 kHz 2: 5.0 kHz 3: 8.0 kHz 4: 10.0 kHz 5: 12.5 kHz 6: 15.0 kHz 7 to A: Swing PWM1 to 4 F: User defined
Frequency References		
d1-01 to d1-16	Frequency Reference 1 to 16	Set the multi-speed references 1 to 16
d1-17	Jog Speed	Jog speed

Par.	Name	Description
V/f Pattern		
E1-01	Input Voltage Setting	Input Voltage
E1-04	Max. Output Freq.	For a linear V/f characteristics, set the same values for E1-07 and E1-09. In this case, the setting for E1-08 will be disregarded.
E1-05	Max. Output Voltage	Ensure that the four frequencies are set according to these rules or OPE10 fault will occur:
E1-06	Base Frequency	$E1-04 \geq E1-06 \geq E1-07 \geq E1-09$
E1-07	Middle Output Freq.	
E1-08	Mid. Output Voltage	
E1-09	Min. Output Freq.	
E1-10	Min. Output Voltage	<p style="text-align: center;">Output voltage</p> <p style="text-align: center;">Output frequency</p>
E1-13	Base Voltage	
Motor Data		
E2-01	Motor Rated Current	Automatically set during Auto-Tuning.
E2-02	Motor Rated Slip	Motor rated slip in hertz (Hz). Automatically set by Rotational Auto-Tuning.
E2-03	Motor No-Load Current	Magnetizing current in Ampere. Automatically set by Rotational Auto-Tuning.
E2-04	Motor Poles	Number of motor poles. Automatically set by Auto-Tuning.
E2-05	Motor Line-to-Line Resistance	Sets the phase-to-phase motor resistance in ohms. Automatically set by Auto-Tuning.
E2-06	Motor Leakage Inductance	Sets the voltage drop due to motor leakage inductance as a percentage of motor rated voltage. Automatically set by Auto-Tuning.

## 6 Parameter Table

Par.	Name	Description
Digital Input Settings		
H1-01 to H1-06	DI S1 to S6 Function Selection	Selects the function of terminals S1 to S6.
A list of the major functions can be found at the table end.		
Digital Output Settings		
H2-01	DO MA/MB Function	Set the function for the relay output MA-MB-MC.
H2-02	DO P1 Function	Sets the function for the photocoupler output P1.
H2-03	DO P2 Function	Sets the function for the photocoupler output P2.
Major functions are listed at the end of the table.		
Analog Input Setting		
H3-01	A1 Signal Level Sel.	<b>0:0 to +10 V (neg. input is zeroed)</b> 1:0 to +10 V (bipolar input)
H3-02	A1 Function Sel.	Assign a function to terminal A1.
H3-03	A1 Gain	Sets the input value in % at 10 V analog input.
H3-04	A1 Bias	Sets the input value in % at 0 V analog input.
H3-09	A2 Signal Level Selection	0:0 to +10 V (neg. input is zeroed) 1:0 to +10 V (bipolar input) <b>2:4 to 20 mA (9 bit input)</b> 3:0 to 20 mA
H3-10	A2 Function Sel.	Assign a function to terminal A2.
H3-11	A2 Gain	Sets the input value in % at 10 V / 20 mA analog input.
H3-12	A2 Bias	Sets the input value in % at 0 V / 0 mA / 4 mA analog input.
Analog Input Setting		
H4-01	AM Monitor Selection	Enter value equal to U1-□□ monitor values. Example: Enter "103" for U1-03.
H4-02	AM Gain	Sets terminal AM output voltage equal to 100% monitor value.
H4-02	AM Bias	Sets terminal AM output voltage equal to 0% monitor value.

Par.	Name	Description
Pulse Input Setting (Free. ref. input)		
H6-02	RP Input Scaling	Sets the number of pulses (in Hz) that is equal to 100% input value.
H6-03	Pulse Train Input Gain	Sets the input value in % at pulse input with H6-02 frequency.
H6-04	Pulse Train Input Bias	Sets the input value in % at 0 Hz pulse input frequency.
Pulse Output Setting		
H6-06	MP Monitor Sel.	Enter value equal to U□-□□ monitor values. Example: Enter "102" for U1-02.
H6-07	MP Monitor Scaling	Sets the number of output pulses when the monitor is 100% (in Hz).
Motor Overheat Protection		
L1-01	Motor Overload Prot. Sel.	Sets the motor overload protection. 0:Disabled <b>1:Standard fan cooled motor</b> 2:Standard blower cooled motor 3:Vector motor
L1-02	Motor Overload Prot. Time	Sets the motor overload protection time in min. Normally no change is necessary.
Stall Prevention		
L3-01	Stall Prevention Selection during Acceleration	0:Disabled - Motor accelerates at active acceleration rate and may stall with too heavy load or too short accel time. <b>1:General Purpose - Hold acceleration when current is above L3-02.</b> 2:Intelligent - Acceleration in the shortest possible time.
L3-02	Stall Prev. Level during Accel.	Sets the current level for stall prevention during acceleration.
L3-04	Stall Prev. Selection during Decel.	0:Disabled - Deceleration as set. OV might occur. <b>1:General Purpose - Deceleration is hold if DC bus voltage rises high.</b>
L3-05	Stall Prev. Selection during Run	0:Disabled - Motor stall or overload might occur. <b>1:Decel Time 1 - Reduce speed using C1-02.</b>

## 6 Parameter Table

Par.	Name	Description
L3-06	Stall Prev. Level during Run	Sets the current level at which stall prevention during run starts to operate.
<b>Auto-Tuning</b>		
T1-01	Auto-Tuning Mode Selection	0: Rotational Auto-Tuning 2: Terminal resistance only 3: Rotational Auto-Tuning for Energy Saving
T1-02	Rated Power	Sets the motor rated power (kW).
T1-03	Rated Voltage	Sets the motor rated voltage (V).
T1-04	Rated Current	Sets the motor rated current (A).
T1-05	Base Frequency	Sets the motor base frequency (Hz).
T1-06	Motor Poles	Sets the number of motor poles.
T1-07	Base Speed	Sets the motor base speed (RPM).
T1-11	Motor Iron Loss	Iron loss for determining the Energy Saving coefficient. If unknown leave it on default.

Monitor	Description
U1-01	Frequency Reference (Hz)
U1-02	Output Frequency (Hz)
U1-03	Output Current (A)
U1-05	Motor Speed (Hz)
U1-06	Output Voltage Reference (Vac)
U1-07	DC Bus Voltage (Vdc)
U1-08	Output Power (kW)
U1-09	Torque Reference (% of motor rated torque)

Monitor	Description
U1-10	<b>Input Terminal Status</b> U1-10=0000000 
U1-11	<b>Output Terminal Status</b> U1-11=000 
U1-12	<b>Drive Status</b> U1-12=00000000 
U1-13	Terminal A1 input level
U1-14	Terminal A2 input level
U1-16	Soft Starter Output (fref after accel./decel. ramps)
U1-18	OPE Fault Parameter
U1-24	Pulse Input frequency

## 6 Parameter Table

Monitor	Description
Fault Trace	
U2-01	Current Fault
U2-02	Previous Fault
U2-03	Frequency Reference at Previous Fault
U2-04	Output Frequency at Previous Fault
U2-05	Output Current at Previous Fault
U2-06	Motor Speed at Previous Fault
U2-07	Output Voltage at Previous Fault
U2-08	DC Bus Voltage at Previous Fault
U2-09	Output Power at Previous Fault
U2-10	Torque Reference at Previous Fault
U2-11	Input Terminal Status at Previous Fault
U2-12	Output Terminal Status at Previous Fault
U2-13	Drive Operation Status at Previous Fault
U2-14	Cumulative Operation Time at Previous Fault
U2-15	Soft-Starter Speed Reference at Previous Fault
U2-16	Motor q-Axis Current at Previous Fault
U2-17	Motor d-Axis Current at Previous Fault
Fault History	
U3-01 to U3-04	Lists the most recent fault that occurred through the fourth most recent fault.
U3-05 to U3-08	Accumulated operation time at the most recent fault through the fourth most recent fault.
U3-09 to U3-14	Lists the fifth most recent fault that occurred through the tenth most recent fault.
U3-15 to U3-20	Accumulated operation time at fifth most recent fault through the tenth most recent fault.
* The following faults are not recorded in the error log: CPF00, 01, 02, 03, UV1, and UV2.	

D/DO Sel.	Description
Digital Input Function Selections	
3	Multi-step speed reference 1
4	Multi-step speed reference 2
5	Multi-step speed reference 3
6	Jog frequency command (higher priority than multi-step speed reference)
7	Accel/decel time selection 1
F	Not used (Set when a terminal is not used)
14	Fault reset (Reset when turned ON)
20 to 2F	External fault; Input mode: N.O. contact / N.C. contact, Detection mode: Normal/during operation
Digital Output Function Selections	
0	During Run (ON: run command is ON or voltage is being output)
1	Zero Speed
2	Speed Agree
6	Drive Ready
E	Fault
F	Not used
10	Minor fault (Alarm) (ON: Alarm displayed)

## 7 Troubleshooting

### ◆ General Fault and Alarms

Faults and alarms indicate problems in the drive or in the machine.

An alarm is indicated by a code on the data display and the flashing ALM LED. The drive output is not necessarily switched off.

A fault is indicated by a code on the data display and the ALM LED is on. The drive output is always switched off immediately and the motor coast to stop.

To remove an alarm or reset a fault, trace the cause, remove it and reset the drive by pushing the Reset key on the operator or cycling the power supply.

**NOTICE!** *This lists up the most important alarms and faults only. Please refer to the instruction manual for a complete list.*

LED Display	ALM	FLT	Cause
Base Block bb	○		The software base block function is assigned to one of the digital inputs and the input is off. The drive does not accept Run commands.
Control Fault CF		○	The torque limit was reached during deceleration for longer than 3 sec. when in Open Loop Vector control <ul style="list-style-type: none"> <li>• The load inertia is too big.</li> <li>• The torque limit is too low.</li> <li>• The motor parameters are wrong.</li> </ul>
Control Circuit Fault [PF02 to PF24]		○	There is a problem in the drive's control circuit.
Option External Fault EF	○	○	An external fault was tripped by the upper controller via an option card.
External Fault EF	○		A forward and reverse command were input simultaneously for longer than 500 ms. This alarm stops a running motor.
External Faults EF1 to EF6	○	○	<ul style="list-style-type: none"> <li>• An external fault was triggered by an external device via one of the digital inputs S1 to S6.</li> <li>• The digital inputs are set up incorrectly.</li> </ul>
Ground Fault GF		○	Ground leakage current has exceeded 50% of the drives rated output current. <ul style="list-style-type: none"> <li>• Cable or motor insulation is broken.</li> <li>• Excessive stray capacitance at drive output.</li> </ul>
Safe Disable Hbb	○		Both Safe Disable inputs are open. The drive output is safely disabled and the motor can not be started.

## 7 Troubleshooting

LED Display	ALM	FLT	Cause
Safe Disable Fault <i>HbbF</i>	○		<p>Drive output is disabled while only one of the Safe Disable inputs is open. (normally both input signals H1 and H2 should be open)</p> <ul style="list-style-type: none"> <li>• One channel is internally broken and does not switch off, even if the external signal is removed.</li> <li>• Only one channel is switched off by the upper controller.</li> </ul>
Output Phase Loss <i>L F</i>		○	<ul style="list-style-type: none"> <li>• Output cable is disconnected or the motor winding is damaged.</li> <li>• Loose wires at the drive output.</li> <li>• Motor is too small (less than 5% of drive current).</li> </ul>
Overcurrent <i>oL</i>		○	<ul style="list-style-type: none"> <li>• Short circuit or ground fault on the drive output side</li> <li>• The load is too heavy.</li> <li>• The accel./decel. times are too short.</li> <li>• Wrong motor data or V/f pattern settings.</li> <li>• A magnetic contactor was switched at the output.</li> </ul>
Heatsink Overheat <i>oH or oH I</i>	○	○	<ul style="list-style-type: none"> <li>• Surrounding temperature is too high.</li> <li>• The cooling fan has stopped.</li> <li>• The heatsink is dirty.</li> <li>• The airflow to the heatsink is restricted.</li> </ul>
Motor Overload <i>oL I</i>		○	<ul style="list-style-type: none"> <li>• The motor load is too heavy.</li> <li>• The motor is operated at low speed with heavy load.</li> <li>• Cycle times of accel./ decel. are too short.</li> <li>• Incorrect motor rated current has been set.</li> </ul>
Drive Overload <i>oL o</i>		○	<ul style="list-style-type: none"> <li>• The load is too heavy.</li> <li>• The drive capacity is too small.</li> <li>• Too much torque at low speed.</li> </ul>
DC Overvoltage <i>oU</i>	○	○	<p>DC bus voltage rose too high.</p> <ul style="list-style-type: none"> <li>• The deceleration time is too short.</li> <li>• Stall prevention is disabled.</li> <li>• Braking chopper / resistor broken.</li> <li>• Unstable motor control in OLV.</li> <li>• Too high input voltage.</li> </ul>
Input Phase Loss <i>oF</i>		○	<ul style="list-style-type: none"> <li>• Input voltage drop or phase imbalance.</li> <li>• One of the input phase is lost.</li> <li>• Loose wires at the drive input.</li> </ul>
Braking Transistor Fault <i>rr</i>		○	<p>The internal braking transistor is broken.</p>
Fault Reset During Run <i>rUn</i>	○		<p>Fault reset was input when a run command was active.</p>
DC Undervoltage <i>Uu I</i>	○	○	<p>The voltage in the DC bus fell below the undervoltage detection level (L2-05).</p> <ul style="list-style-type: none"> <li>• The power supply failed or one input phase has been lost.</li> <li>• The power supply is too weak.</li> </ul>

LED Display	ALM	FLT	Cause
Controller Undervoltage <i>Uu2</i>		○	The drives controller power supply voltage is too low.
DC Charge Circuit Fault <i>Uu3</i>		○	The charge circuit for the DC bus is broken.

### ◆ Operator Programing Errors

An Operator Programming Error (OPE) occurs when an inapplicable parameter is set or an individual parameter setting is inappropriate. When an OPE error is displayed, press the ENTER button to display U1-18 (OPE fault constant). This monitor will display the parameter that is causing the OPE error.

LED Operator Display	Cause	Corrective Action
oPE01 <i>oPE01</i>	Drive capacity and value set to o2-04 do not match.	Correct the value set to o2-04.
oPE02 <i>oPE02</i>	Parameters were set outside the allowable setting range.	Set parameters to the proper values.
oPE03 <i>oPE03</i>	<p>A contradictory setting is assigned to multi-function contact inputs H1-01 through to H1-06 .</p> <ul style="list-style-type: none"> <li>• The same function is assigned to two inputs (this excludes “External fault” and “Not used”)</li> <li>• Input functions which require the setting of other input functions were set alone.</li> <li>• Input functions that are not allowed to be used simultaneously have been set.</li> </ul>	<ul style="list-style-type: none"> <li>• Fix any incorrect settings.</li> <li>• Refer to the instruction manual for more details.</li> </ul>
oPE05 <i>oPE05</i>	<ul style="list-style-type: none"> <li>• The run command source (b1-02) or frequency reference source (b1-01) is set to 3 but no option board is installed.</li> <li>• The frequency reference source is set to pulse input but H6-01 is not 0.</li> </ul>	<ul style="list-style-type: none"> <li>• Install the required option board.</li> <li>• Correct the values set to b1-01 and b1-02.</li> </ul>
oPE07 <i>oPE07</i>	<p>Settings to multi-function analog inputs H3-02 and H3-10 and PID functions conflict.</p> <ul style="list-style-type: none"> <li>• H3-02 and H3-10 are set to the same value (this excludes settings “0” and “F”)</li> <li>• PID functions have been assigned to both analog inputs and the pulse input at the same time.</li> </ul>	<ul style="list-style-type: none"> <li>• Fix any incorrect setting.</li> <li>• Refer to the instruction manual for more details.</li> </ul>
oPE08 <i>oPE08</i>	A function has been set that cannot be used in the control mode selected (might appear after control mode change)	<ul style="list-style-type: none"> <li>• Fix any incorrect setting.</li> <li>• Refer to the instruction manual for more details.</li> </ul>
oPE10 <i>oPE10</i>	The V/f pattern setting is incorrect.	<ul style="list-style-type: none"> <li>• Check the V/f pattern settings.</li> <li>• Refer to the instruction manual for more details.</li> </ul>

## 7 Troubleshooting

### ◆ Auto-Tuning Errors

LED Operator Display	Cause	Corrective Action
Er-01 <i>Er-01</i>	Motor data fault The input motor data are not valid (e.g. the base frequency and base speed do not fit).	Re-enter the data and repeat Auto-Tuning.
Er-02 <i>Er-02</i>	Minor Fault • The wiring is faulty. • The load is too heavy.	<ul style="list-style-type: none"> <li>• Check the wiring.</li> <li>• Check the load. Always perform Auto-Tuning with the load decoupled from the motor.</li> </ul>
Er-03 <i>Er-03</i>	The STOP button was pressed and Auto-Tuning was canceled.	Repeat the Auto-Tuning.
Er-04 <i>Er-04</i>	Resistance fault • Wrong input data. • Auto tuning exceeded the given time frame. • Calculated values out of range.	<ul style="list-style-type: none"> <li>• Check the input data.</li> <li>• Check the wiring.</li> <li>• Re-enter the data and repeat the Auto-Tuning.</li> </ul>
Er-05 <i>Er-05</i>	No-Load Current Error • Incorrect data was entered. • Auto tuning took too long. • Calculated values out of range.	
Er-08 <i>Er-08</i>	Rated Slip Error • Wrong data input. • Auto tuning exceeded the given time frame. • Calculated values out of range.	
Er-09 <i>Er-09</i>	Acceleration error The motor did not accelerate for the specified acceleration time.	<ul style="list-style-type: none"> <li>• Increase the acceleration time C1-01.</li> <li>• Check the torque limits L7-01 and L7-02.</li> </ul>
Er-11 <i>Er-11</i>	Motor speed fault. The torque reference was too high.	<ul style="list-style-type: none"> <li>• Increase the acceleration time (C1-01).</li> <li>• If possible, disconnect the load.</li> </ul>
Er-12 <i>Er-12</i>	Current detection error • One or all output phases are lost. • Current is either too low or exceeds the drives rating. • The current sensors are faulty.	<ul style="list-style-type: none"> <li>• Check the wiring.</li> <li>• Make sure, that the drive rating fits to the motor.</li> <li>• Check the load. (Auto-Tuning should have been performed without the load connected).</li> <li>• Replace the drive.</li> </ul>
End1 <i>End1</i>	Rated current alarm • The torque reference exceeded 20% during Auto-Tuning. • The calculated no-load current is above 80% of the motor rated current.	<ul style="list-style-type: none"> <li>• Check the V/f pattern setting.</li> <li>• Perform Auto-Tuning without the load connected.</li> <li>• Check the input data and repeat Auto-Tuning.</li> </ul>
End2 <i>End2</i>	Motor iron-core saturation alarm • Calculated core saturation values out of range. • Incorrect data was entered.	<ul style="list-style-type: none"> <li>• Check the input data.</li> <li>• Check the motor wiring.</li> <li>• Perform Auto-Tuning without load connected.</li> </ul>
End3 <i>End3</i>	Rated current alarm	Check the input data and repeat tuning.

**OMRON EUROPE B.V.** Wegalaan 67-69, NL-2132 JD, Hoofddorp, The Netherlands.  
Tel: +31 (0) 23 568 13 00 Fax: +31 (0) 23 568 13 88 [www.omron-industrial.com](http://www.omron-industrial.com)

**Austria**  
Tel: +43 (0) 1 80 19 00  
[www.omron.at](http://www.omron.at)

**Belgium**  
Tel: +32 (0) 2 466 24 80  
[www.omron.be](http://www.omron.be)

**Czech Republic**  
Tel: +420 234 602 602  
[www.omron.cz](http://www.omron.cz)

**Denmark**  
Tel: +45 43 44 00 11  
[www.omron.dk](http://www.omron.dk)

**Finland**  
Tel: +358 (0) 207 464 200  
[www.omron.fi](http://www.omron.fi)

**France**  
Tel: +33 (0) 1 56 63 70 00  
[www.omron.fr](http://www.omron.fr)

**Germany**  
Tel: +49 (0) 2173 680 00  
[www.omron.de](http://www.omron.de)

**Hungary**  
Tel: +36 (0) 1 399 30 50  
[www.omron.hu](http://www.omron.hu)

**Italy**  
Tel: +39 02 32 681  
[www.omron.it](http://www.omron.it)

**Middle East & Africa**  
Tel: +31 (0) 23 568 11 00  
[www.omron-industrial.com](http://www.omron-industrial.com)

**Netherlands**  
Tel: +31 (0) 23 568 11 00  
[www.omron.nl](http://www.omron.nl)

**Norway**  
Tel: +47 (0) 22 65 75 00  
[www.omron.no](http://www.omron.no)

**Poland**  
Tel: +48 (0) 22 645 78 60  
[www.omron.com.pl](http://www.omron.com.pl)

**Portugal**  
Tel: +351 21 942 94 00  
[www.omron.pt](http://www.omron.pt)

**Russia**  
Tel: +7 095 745 26 64  
[www.omron.ru](http://www.omron.ru)

**Spain**  
Tel: +34 913 777 900  
[www.omron.es](http://www.omron.es)

**Sweden**  
Tel: +46 (0) 8 632 35 00  
[www.omron.se](http://www.omron.se)

**Switzerland**  
Tel: +41 (0) 41 748 13 13  
[www.omron.ch](http://www.omron.ch)

**Turkey**  
Tel: +90 (0) 216 474 00 40 Pbx  
[www.omron.com.tr](http://www.omron.com.tr)

**United Kingdom**  
Tel: +44 (0) 870 752 08 61  
[www.omron.co.uk](http://www.omron.co.uk)

Manufacturer



YASKAWA ELECTRIC CORPORATION

YASKAWA

In the event that the end user of this product is to be the military and said product is to be employed in any weapons systems or the manufacture thereof, the export will fall under the relevant regulations as stipulated in the Foreign Exchange and Foreign Trade Regulations. Therefore, be sure to follow all procedures and submit all relevant documentation according to any and all rules, regulations and laws may apply.  
Specifications are subject to change without notice for ongoing product modifications and improvements.

© 2007 OMRON Yaskawa Motion Control. All rights reserved.

Note: Specifications subject to change without notice.  
Manual No. i67E-EN-01

